

Diaphragm seal

HYGIENIC Tubus Ø 101 mm with clamp connection

Type series DL8140



Application area

- Food industry
- Pharmaceutical industry
- Biotechnology

Features

- Flush-mounted separating diaphragm of stainless steel, laser welded
- With reinforced diaphragm in LTC technology (reduced temperature influence)
- Volume optimised diaphragm base
- System fillings for different applications
- Measuring device connection:
 - directly welded
 - directly screwed
 - with temperature decoupler
 - with capillary

Options

- Labom REconnect quick coupling device for easy and safe separation and connection of diaphragm seal systems. Available with a wide range of pressure gauges and pressure transmitters; Type series MK1000, see data sheet D6-022
- Certificates
 - Material certificate acc. to EN 10204-3.1
- Electropolishing (wetted parts)
- Hygienic design with advanced surface quality
- Special materials upon request

Application

Suitable for mounting to bourdon tube pressure gauges and pressure transmitters. The diaphragm seal HYGIENIC Tubus is used mainly for dead-zone free pressure measurement.

Technical data

Constructional design

Basic body:	Volume reduced diaphragm base Material: stainless steel mat.-no. 1.4404/1.4435 (316L)
Diaphragm:	Flush-mounted diaphragm, laser welded; with reduced temperature influence and reinforced diaphragm in LTC technology. (LTC=Low Temperature Coefficient, further details see General technical information TA_031).
Material wetted parts:	Diaphragm: Stainless steel mat.-no. 1.4435 (316L) Further materials upon request Basic body: Stainless steel mat.-no. 1.4404/1.4435 (316L)

Process connection

Design:	HYGIENIC Tubus: Ø 101 mm
Diaphragm surface:	Ø 85 mm
Nominal pressure:	PN 10
Gasket:	<ul style="list-style-type: none">■ Material EPDM, FDA compliant Temperature range: -45...150 °C■ Material FKM O-ring (Viton) Temperature range: -40...200 °C

Measuring device connection

See order details.
Material stainless steel mat.-no. 1.4301 (304)

System filling

See order details; further upon request.
Further details about pressure transmission fluids see general technical information TA_038.

Hygienic design

The surface roughness of the wetted parts made of stainless steel are executed according to EHEDG Doc.8 and ASME BPE SF3.
In case of choosing the additional feature HY, we guarantee the following surface roughness values:

Diaphragm foil:	Ra ≤ 0.38 µm
Laser welds:	Ra ≤ 0.76 µm
Turned parts:	Ra ≤ 0.76 µm

Further versions of hygienic design upon request.

Weight

With measuring device connection G1/2 approx. 4.5 kg

Further information about diaphragm seals see general technical information TA_031.

Flame arrester MF21xx for connection of measuring devices to zone 0 see data sheet D6-025.

Measuring device connection

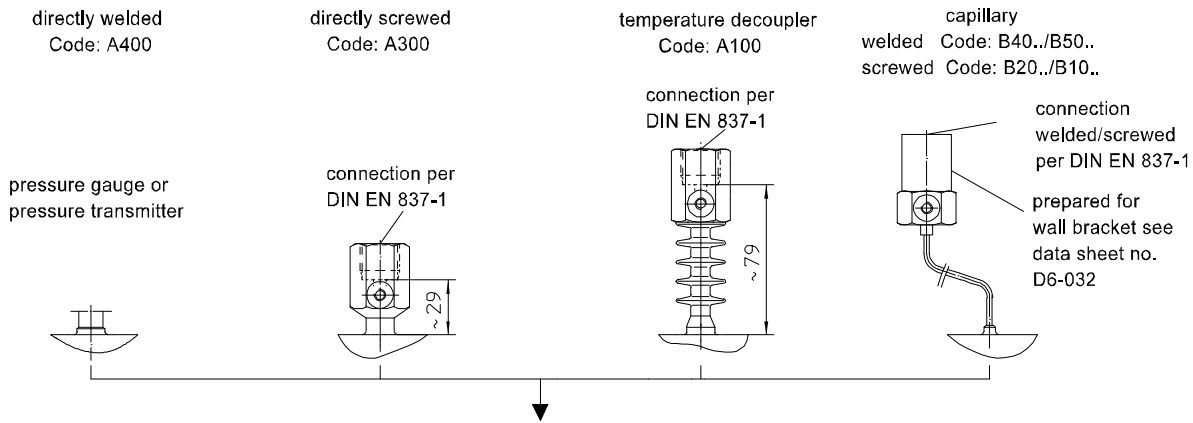

Dimensions

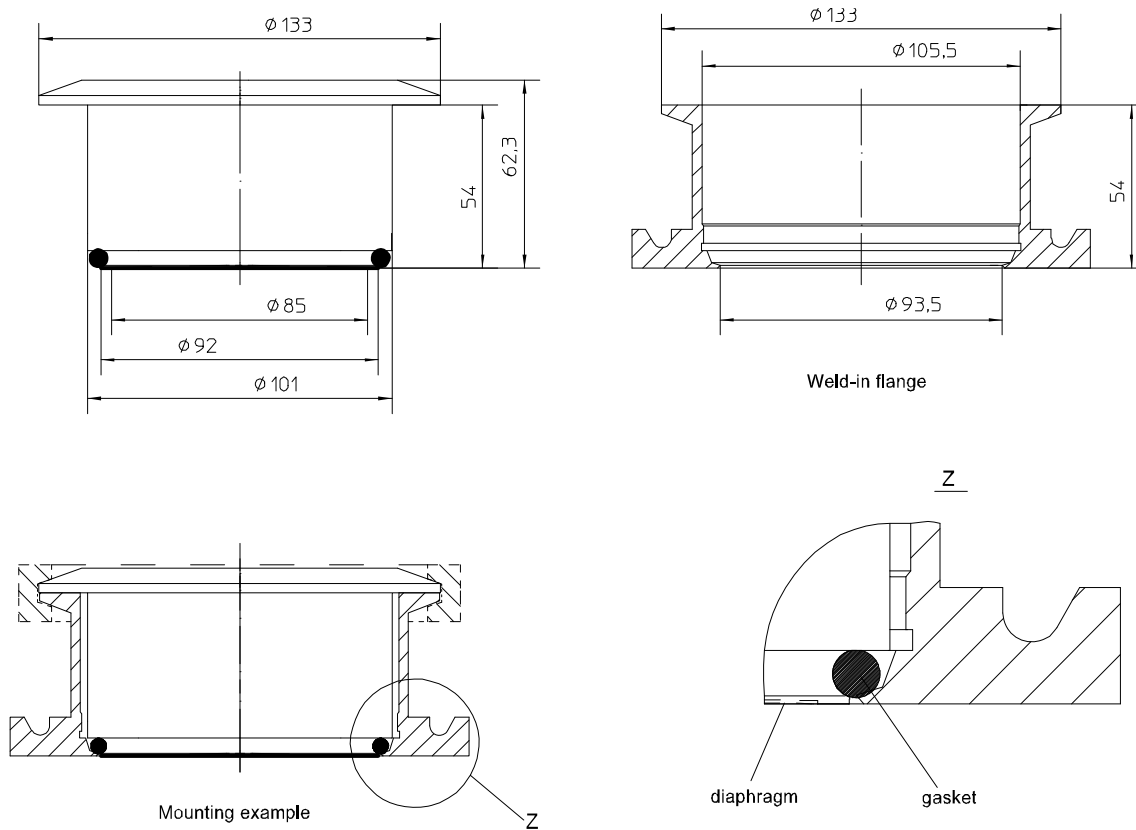

Order details

Diaphragm seal HYGIENIC Tubus Ø101 mm with clamp connection Type series DL8140

Order details diaphragm seal DL8140

DL8140	design	HYGIENIC Tubus Ø 101 mm	
HY	surface roughness	Hygienic version as per EHEDG Doc.8 and ASME BPE SF3	
E1	basic body material	stainless steel mat.-no. 1.4404/1.4435 (316L)	
G1L	diaphragm material	stainless steel mat.-no. 1.4404/1.4435 (316L), diaphragm in LTC technology	
H2	gasket	EPDM, FDA compliant, temperature range -45...150 °C	
H7		FKM O-ring (Viton), temperature range -40...200 °C	
A400	measuring device connection	directly	welded
A300			screwed G1/2
A100		with temperature decoupler	screwed G1/2
B40..		with capillary	welded
B20..			screwed G1/2
B50..		with capillary and stainless steel protective tube	welded
B10..			screwed G1/2
11		capillary length	1 m
12			1.6 m
13			2.5 m
14			4 m
21			5 m
15			6 m
23			7 m
16	8 m		
17	10 m		
9	others		
	system filling ¹	<u>pressure transmission fluid</u>	<u>temperaturr range²</u>
L22		synthetic oil, free of silicone FD1, standard	-10...140 °C
L23		synthetic oil, free of silicone FD1, please specify max. temperature	-40...230 °C
L32		Neobee FNM20	-20...260 °C

Additional features (to be indicated in case of need, only)

W1020	material certificate acc. to EN 10204-3.1, wetted parts
W4035	electropolishing of wetted parts

Accessories

MZ2030-HY-E1	weld-in flange, stainless steel mat.-no. 1.4435 (316L), hygienic design
MZ8110	mounting bracket

Order code (example): DL8140 - HY - E1 - G1L - H2 - A400 - L23 - ...

¹ for more detailed information about pressure transmission fluids see TA_038.
Please state temperature range to allow an accurate calculation of the system.

² max. media temperature for pressures > 0 bar rel. The temperature range of the used gasket has to be observed.